

thermal invariant points in the ternary systems where the stable form of $\text{CaCl}_2 \cdot 4\text{H}_2\text{O}$ is one of the solid phases. The effect of metastable form in these ternary systems was not determined. Hence MP' and EQ' are not true saturation curves for the metastable equilibria. However, it is possible to make an assumption as to the general effect of $\text{CaCl}_2 \cdot 4\text{H}_2\text{O} \gamma$ on the ternary systems. In the ternary system $\text{CaCl}_2\text{-KCl-H}_2\text{O}$ the invariant point would be of slightly higher calcium chloride content with the potassium chloride content remaining about the same. The effect on the $\text{CaCl}_2\text{-MgCl}_2\text{-H}_2\text{O}$ system would be more pronounced in that the tachyrite area would be larger, occupying some of the space now covered by $\text{CaCl}_2 \cdot 4\text{H}_2\text{O} \alpha$. The $\text{CaCl}_2 \cdot 4\text{H}_2\text{O} \gamma$ field would be very small.

In Table II the data for the quaternary isotherm are given based on the salt content of the saturated solution exclusive of water. The plot of the data is shown in Fig. 5. Coexistent solid phases have been connected by straight lines and the triangles outlined by them represent the three solid phases present at the invariant points. The lines and points follow the consistent notation used in the other projections. The Jänecke diagram for the metastable relations is very similar to Fig. 5.

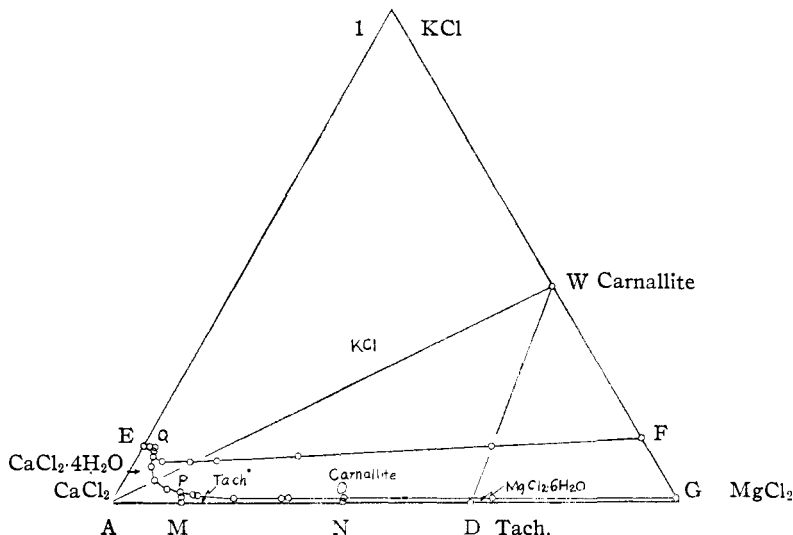

Fig. 5.—Quaternary system $\text{CaCl}_2\text{-MgCl}_2\text{-KCl-H}_2\text{O}$ at 35° , projected on base of tetrahedron.

Summary

1. Isotherms have been determined at 35° for the quaternary system $\text{MgCl}_2\text{-CaCl}_2\text{-KCl-H}_2\text{O}$.

RECEIVED AUGUST 23, 1948

[CONTRIBUTION FROM THE DEPARTMENT OF CHEMISTRY, HARVARD UNIVERSITY]

Polarography of Selenium and Tellurium. I. The -2 States

BY JAMES J. LINGANE AND LEONARD W. NIEDRACH¹

Investigations of the polarographic behavior of the -2 oxidation states of selenium and tellurium have not been reported in the literature. In the case of sulfide ion in 1 *N* sodium hydroxide Revenda,^{2a} and Kolthoff and Miller,² observed a single, well-developed anodic wave due to the reaction $\text{Hg} + \text{S}^{2-} = \text{HgS} + 2e$. We have found that selenide and telluride ions produce similar anodic waves. The reaction of selenide ion is analogous to that of sulfide ion, *i. e.*, primary oxidation of the mercury of the dropping electrode and the subsequent precipitation of mercuric selenide. In the case of telluride ion, however, we have obtained evidence that the anodic wave results from oxidation of the telluride ion itself to the element, rather than "depolarization" of the dropping mercury anode.

Experimental

The selenide and telluride solutions used for these experiments were obtained by controlled potential electrolytic reduction at a mercury cathode of the purified dioxides whose preparations have been previously described.³

The reductions were performed in the diaphragm cell shown in Fig. 1 and the cathode potential was controlled against a saturated calomel reference electrode by an automatic potentiostat.⁴ The reduction of tellurium(IV) was performed in 1 *N* sodium hydroxide at a potential of -1.7 v. vs. the S.C.E., while the selenium(IV) was reduced in a 1 *M* ammoniacal chloride buffer at pH 8.0 and a potential of -1.8 v. The reduced solution in the cell was sometimes used directly for the polarographic measurements, while in other cases aliquots were transferred to supporting electrolytes in a conventional H-type cell.

The diaphragm cell in Fig. 1 has been modified from that previously described⁵ to incorporate a reference electrode as an integral part so that polarograms could be recorded without disturbing the contents of the cell. The cathode chamber is a 250-cc. wide-mouthed erlenmeyer flask, which is joined to the anode chamber and the reference electrode through 30 mm. and 10 mm. medium porosity sintered-glass disks, respectively. Provision is also made for sweeping the solution with an inert gas and for electrical contact with the mercury cathode. The four-hole rubber stopper accommodates the dropping mercury electrode, a propeller type glass stirrer which agitates the mercury-solution interface as well as the solution, an additional gas entry, and a salt bridge to an external reference electrode for use during the electrolysis. To minimize the inclusion of *iR* drop in the measured cathode potential the tip of the salt bridge must be as close to the mercury as is physically possible.⁵ A carbon rod served as anode. A layer of agar saturated with potassium chloride was placed on the anode side of the

(1) Allied Chemical and Dye Corporation Fellow, 1947-48.

(2) (a) J. Revenda, *Coll. Czechoslov. Chem. Commun.*, **6**, 453 (1934);

(b) I. M. Kolthoff and C. S. Miller, *THIS JOURNAL*, **63**, 1405 (1941).

(3) J. J. Lingane and L. W. Niedrach, *ibid.*, **70**, 1997 (1948).

(4) J. J. Lingane, *Ind. Eng. Chem., Anal. Ed.*, **17**, 332 (1945).

(5) J. J. Lingane, C. G. Swain and M. Fields, *THIS JOURNAL*, **65**, 1348 (1943).

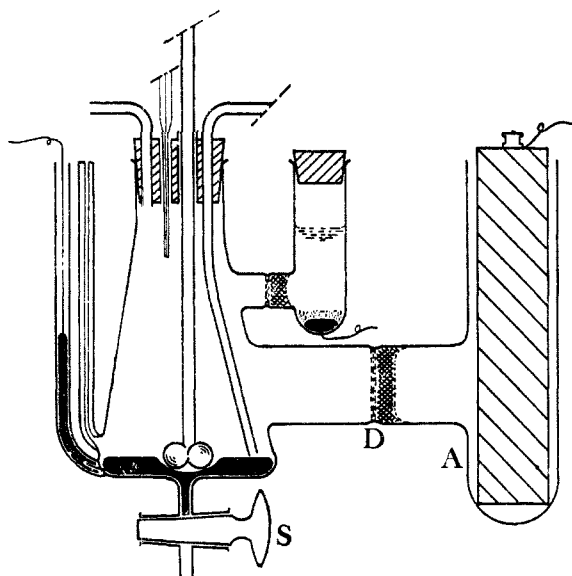

Fig. 1.—Cell for controlled potential electrolytic preparations.

disk between the cathode and anode chambers to prevent interflow of the catholyte and anolyte.

All of the polarograms were obtained with a photographically recording instrument of the Heyrovsky-Shikata type,⁶ constructed by Mr. Lyndon Small and the junior author. The design of the instrument is similar to that described by Lingane⁷ with a calibrated, ten-turn, 100-ohm Beckman Helipot as the potentiometer bridge. For manual measurements a conventional circuit⁸ was employed.

The m value of the dropping electrode was determined with the automatic apparatus previously described,⁹ and the drop times were measured at the potentials at which the diffusion currents were measured.

All measurements were made at $25.00 \pm 0.05^\circ$, and the solutions contained 0.003% gelatin as a maximum suppressor. A saturated calomel reference electrode was employed. Purified hydrogen was used to displace dissolved air from the solutions.

Results and Discussion

-2 Selenium.—The polarograms in Fig. 2 were obtained with an ammoniacal supporting electrolyte (pH 8.0) containing 0.003% gelatin. The blank was run after electrolyzing 250 cc. of the supporting electrolyte at -1.9 v. vs. the S.C.E. for several minutes to remove the dissolved oxygen. Successive additions of $+4$ selenium were then electrolyzed at -1.8 v., and polarograms were recorded after the complete reduction of each increment to the -2 state without removing the solutions from the preparative cell. Upon the addition of $+4$ selenium to the solutions containing -2 selenium a rapid reaction occurred that resulted in a colloidal dispersion of red selenium which then underwent reduction to selenide ion.

Figure 3 shows tracings of polarograms obtained by adding 2-cc. aliquots of a 1.4 millimolar

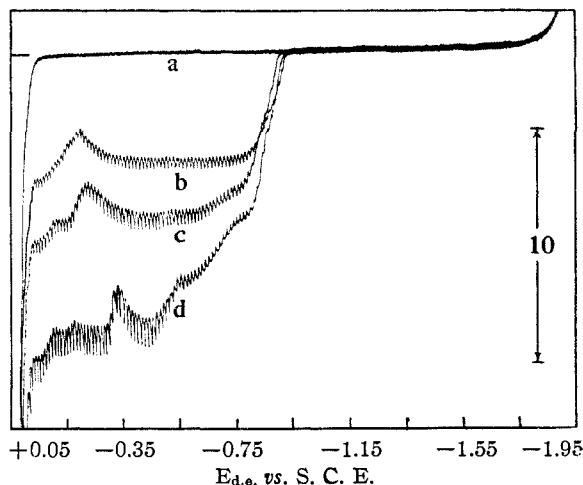

Fig. 2.—Polarograms of -2 selenium in ammoniacal medium. Solutions contained 1 M ammonium chloride, 0.003% gelatin, and sufficient ammonia to adjust the pH to 8.0. The concentrations of -2 selenium were (a) 0, (b) 0.58, (c) 0.86 and (d) 1.4 millimolar. Arrow distance is $10 \mu a$.

-2 selenium solution to 20 cc. of the desired oxygen-free supporting electrolyte. The pH of the solutions was measured with the glass electrode. The galvanometer zero was shifted progressively downward in recording the several curves, but the same voltage scale applies to all of them. All of the waves are anodic.

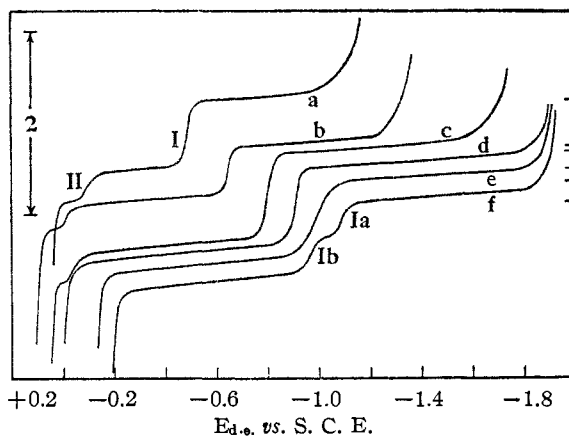

Fig. 3.—Polarograms of -2 selenium in solutions of various pH . Approximately 0.13 millimolar -2 selenium and 0.003% gelatin in (a) 1 N hydrochloric acid, pH 0.1; (b) 0.5 M citrate buffer, pH 2.5; (c) ammonia-1 M ammonium chloride, pH 8.0; (d) 0.5 M sodium carbonate, pH 10.7; (e) 1 M sodium chloride plus sodium hydroxide to pH 12.3; and (f) 1 M sodium hydroxide, pH 13.9. The same voltage scale applies to all the curves. The galvanometer zero was shifted progressively downward, and is indicated for each curve by the marks on the right-hand ordinate. Arrow distance is $2 \mu a$.

(6) I. M. Kolthoff and J. J. Lingane, "Polarography," Interscience Publishers, Inc., New York, N. Y., 1946.

(7) J. J. Lingane, *THIS JOURNAL*, **68**, 2448 (1946).

(8) J. J. Lingane and I. M. Kolthoff, *ibid.*, **61**, 825 (1939).

(9) J. J. Lingane, *Ind. Eng. Chem., Anal. Ed.*, **16**, 329 (1944).

During transfer from the preparative to the polarographic cell, a slight amount of oxidation

occurred, and in the more acid solutions some hydrogen selenide escaped during mixing. Since the diffusion current constants were of secondary interest in these experiments the loss of hydrogen selenide was not considered serious.

Most of the polarograms exhibit two waves which may be attributed to reactions of -2 selenium. The main wave, I in Fig. 3, shifts markedly to more negative potentials with increasing pH.

In order to determine the number of electrons involved in the anodic reaction corresponding to wave I a coulometric analysis¹⁰ of a selenide solution was carried out. Two hundred and fifty cc. of a 1.46 millimolar solution of -2 selenium in an ammonia-1 M ammonium chloride solution of pH 8.0 was electrolyzed at a potential of -0.4 v. vs. the S.C.E. with a hydrogen-oxygen coulometer in series with the electrolysis cell. Upon completion of the electrolysis the current decreased completely to zero, and from the volume of gas evolved in the coulometer it was found that 2.07 electrons were required for the oxidation, in good agreement with the theoretical 2. The electrolysis product of the coulometric analysis was a finely divided black material, which qualitative tests showed to be a mercury compound. From analogy with the sulfides (mercurous sulfide is unstable relative to mercuric sulfide and mercury) and the fact that the existence of mercurous selenide is questionable, it was concluded that the oxidation product is mercuric selenide.

At pH values up to 12.3 the single main wave I results from the anodic depolarization of the dropping electrode by hydrogen selenide, hydrogen selenide ion or selenide ion depending on the pH,

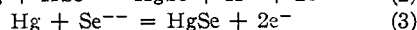
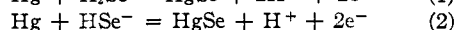
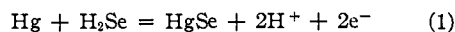

The negative shift of the half-wave potential with increasing pH reflects the fact that hydrogen ion is a product of the anodic reaction, or in other words, that the solubility of mercuric selenide is a function of pH.

In 1 M sodium hydroxide (curve *f* in Fig. 3) wave I is resolved into two parts which we attribute to successive oxidation reactions

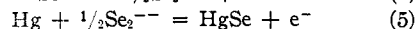
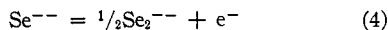

This mechanism is indicated by the equality of the heights of the two waves, which persists over the concentration range 0.068 to 0.238 millimolar.

The wave II in the neighborhood of 0 v. between pH 0.1 and 8 is apparently due to further oxidation, the full development being hindered by a rate controlled reaction. This wave does not appear in the more alkaline supporting electrolytes because of masking by the dissolution wave of mercury.

At pH 8.0 well developed waves are obtained only from solutions containing less than about 0.6

millimolar -2 selenium (Fig. 2). The form becomes very distorted as the concentration is increased. This behavior is analogous to the distortions of the anodic waves of iodide and bromide.^{1,2} As in those cases, the distortion at the higher concentrations is probably due to the formation of an insoluble film of the oxidation product on the surface of the dropping mercury.

The diffusion current constants are summarized in Table I, where $I = i_a/(Cm^2/t^{1/2})$. In the acid solutions these values should be considered as lower limits only, because of the noticeable tendency for hydrogen selenide to escape from solution. In the alkaline region the magnitude of the diffusion current constant for the main wave remains fairly constant.

TABLE I
ANODIC DIFFUSION CURRENT CONSTANTS OF -2 SELENIUM AT VARIOUS pH VALUES

pH	C millimolar	Temp., 25°C.	
		$m^{2/3}t^{1/6} = 1.54$ I_1	I_{II} (Total)
0.1	0.13	3.8	5.1
	.24	3.7	5.1
2.5	.13	2.7	4.4
	.13	4.0	...
8.0	.13	4.5	6.1
	.24	5.0	6.2
	.29	5.0	6.0
	.58	5.2	5.9
10.0	.13	4.5	...
12.3	.13	4.3	...
		I_{Ia}	I_{Ib} (Total)
13.9	.068	2.1	3.8
	.13	1.95	3.78
	.24	1.80	3.76

It is of interest to compare the observed effect of pH on the half-wave potential of the main wave with the behavior predicted from thermodynamic data. In deriving the necessary relations the treatment is based on the equilibria represented by Eqns. 1, 2 and 3.

For reaction 1 under conditions of thermodynamic reversibility the potential of the dropping electrode will be given by

$$E = E^0 - \frac{0.059}{2} \log \frac{C_{\text{H}_2\text{Se}}^0}{(C_{\text{H}^+}^0)^2} \quad (6)$$

where E^0 is the standard potential of reaction 1 and the superscripts ⁰ on the concentration terms denote the concentrations of hydroselenic acid and hydrogen ion at the electrode surface as distinct from the concentrations in the body of the solution. Strictly, activities rather than concentrations should be used but the appropriate activity coefficients are not available. Since the solutions used were well-buffered, the activity of hydrogen ion at the electrode surface may be taken equal to that in the bulk of the solution, which, as a good approximation, may be computed from the measured pH values.

(10) J. J. Lingane, THIS JOURNAL, 67, 1916 (1945).

The total concentration C of -2 selenium is distributed according to

$$C = C_{\text{H}_2\text{Se}} + C_{\text{HS}_2^-} + C_{\text{S}} = \quad (7)$$

When the concentrations of the three species are related to C and the hydrogen ion concentration by means of the dissociation constants K_1 and K_2 of hydroselenic acid, the concentration of hydroselenic acid is expressible as a function of hydrogen ion concentration by

$$C_{\text{H}_2\text{Se}} = \frac{CC_{\text{H}^+}^2}{C_{\text{H}^+}^2 + C_{\text{H}^+}K_1 + K_1K_2} = \frac{CC_{\text{H}^+}^2}{Z} \quad (8)$$

where $Z = C_{\text{H}^+}^2 + K_1C_{\text{H}^+} + K_1K_2$. In well-buffered solutions the ratio $C_{\text{H}_2\text{Se}}/C$ at the electrode surface will be the same as in the body of the solution.

Since the limiting current is diffusion controlled, the total concentration C^0 of all three forms of -2 selenium at the electrode surface is related to that in the body of the solution by

$$C^0 = C - \frac{i}{k} = \frac{i_d - i}{k} \quad (9)$$

where k is a constant defined by the Ilkovic equation.⁶ At potentials corresponding to the limiting current C^0 becomes negligibly small compared to C , and hence $C = i_d/k$.

When the relations expressed by equations 8 and 9 are substituted into equation 6, we obtain for the equation of the anodic wave

$$E = E^0 + \frac{0.059}{2} \log Z - \frac{0.059}{2} \log \frac{(i_d - i)}{k} \quad (10)$$

and the half-wave potential, corresponding to $i = (i_d/2)$, is given by

$$E_{1/2} = E^0 + \frac{0.059}{2} \log Z - \frac{0.059}{2} \log \frac{C}{2} \quad (11)$$

The standard potential E^0 of reaction 1 has not been directly determined, but it can be estimated from thermal data. From measurements of Fabre,¹¹ on the heat of solution of mercuric selenide in bromine water Bichowsky and Rossini¹² calculated the heat of formation of mercuric selenide to be -3.5 kcal., while from Fabre's measurements of the heat of reaction between mercuric chloride and aqueous sodium selenide solutions they compute the considerably larger value -8.0 kcal. Assuming that the entropy of mercuric selenide is the same as that of mercuric sulfide (19.8 cal. deg.⁻¹),¹³ we compute the entropy of formation of mercuric selenide to be -9.2 cal. deg.⁻¹. This leads to a value of -0.8 kcal. for the free energy of formation if the heat of formation is -3.5 kcal., or to -5.3 kcal. if the heat of formation is -8.0 kcal. When these values are combined with the free energy of aqueous hydroselenic acid quoted by Latimer¹³ (16.7 kcal.) the corresponding stand-

ard potential of reaction 1 is found to be either $+0.38$ v. or $+0.48$ v. vs. the standard hydrogen electrode. Substituting these values for E^0 into equation 11, we compute that the half-wave potential at $p\text{H}$ 0, and with a concentration of -2 selenium of 1 millimolar, should be either -0.52 v. or -0.62 v. vs. S.C.E. (the negative sign indicating that the dropping electrode is negative to the saturated calomel electrode). At $p\text{H}$ 0.1 and $C = 0.13$ millimolar the corresponding calculated $E_{1/2}$ values are -0.50 v. and -0.60 v. vs. S.C.E. The observed half-wave potential under these latter conditions is -0.490 v., in very good agreement with the first of the two calculated values. This is conclusive proof that equation 1 represents the reaction at the dropping electrode, and that this reaction proceeds reversibly. These data also constitute good evidence that the heat of formation of mercuric selenide is -3.5 kcal. rather than -8.0 kcal.

In order to compute $E_{1/2}$ from eq. 11 over the entire $p\text{H}$ range a knowledge of K_1 and K_2 , which occur in the Z -term, is necessary. From the conductivity measurements of De Hlasko¹⁴ $K_1 = 1.88 \times 10^{-4}$. No experimental value for K_2 is available, but Latimer¹³ estimates $K_2 = 10^{-10}$. From the fact that $E_{1/2}$ increases continuously up to $p\text{H}$ 14, as well as from analogy with the second dissociation constant of hydrogen sulfide (10^{-15}), a value for K_2 of 10^{-10} appears to be too great. We have used $K_2 = 10^{-14}$ as the most probable value.

Curves a and b in Fig. 4 were computed from Eqn. 11 using the theoretical $E_{1/2}$ of -0.50 v. and $K_1 = 1.88 \times 10^{-4}$. Curve a was calculated assuming $K_2 = 10^{-10}$, and curve b by assuming $K_2 = 10^{-14}$. The circles are the experimental half-wave potentials, and their agreement with the theoretical curve b based on $K_2 = 10^{-14}$ is excellent over the entire $p\text{H}$ range from 0 to 14.

From these data the solubility product of mercuric selenide was calculated to be 10^{-59} , which is somewhat smaller than that of mercuric sulfide (10^{-53}). Corresponding to this difference in the solubility products the half-wave potential of the anodic selenide wave is about 0.2 v. more negative than that of sulfide ion in 0.1 N sodium hydroxide, and a simultaneous polarographic determination of these two ions in a mixture should be possible.

-2 Tellurium.—Like sulfide and selenide ions, telluride ion produces a well-developed anodic wave. Typical polarograms in 1 N sodium hydroxide are shown in Fig. 5. The solutions for these experiments were prepared by controlled potential reduction at -1.6 v. vs. the S.C.E. of air-free solutions of purified tellurium dioxide in 1 N sodium hydroxide, and the polarograms were recorded directly with the reduced solutions in the preparative cell of Fig. 1. As in the case of selenium, addition of the $+4$ tellurium to the solutions of telluride ion resulted in the pre-

(11) M. C. Fabre, *Ann. chim. phys.*, [6] **10**, 542 (1887).

(12) F. R. Bichowsky and F. D. Rossini, "The Thermochemistry of the Chemical Substances," Reinhold Publishing Corp., New York, N. Y., 1936.

(13) W. M. Latimer, "Oxidation Potentials," Prentice-Hall, Inc., New York, N. Y., 1938.

(14) M. De Hlasko, *J. chim. phys.*, **20**, 167 (1923).

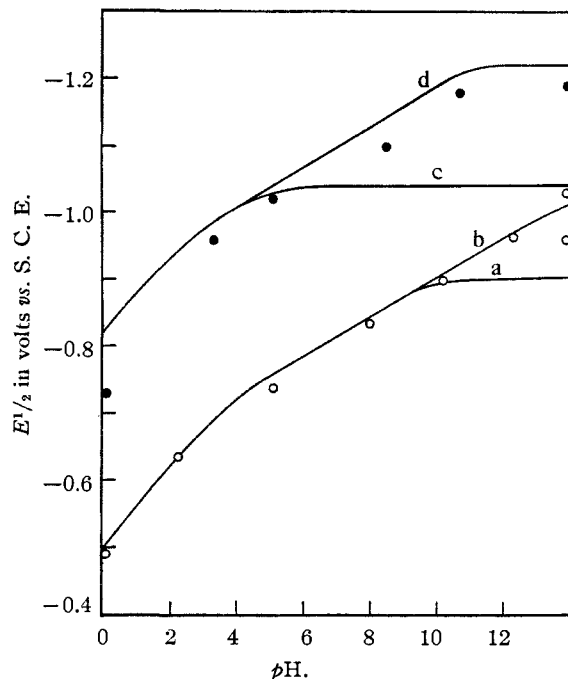
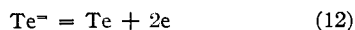

Fig. 4.—Half-wave potentials of the anodic waves of -2 selenium (curves a and b) and -2 tellurium (curves c and d) as a function of pH . The circles are experimental points and the curves represent the theoretically predicted functions.

precipitation of elemental tellurium which then underwent reduction to the -2 state.

In 1 *N* sodium hydroxide the main wave at -1.2 v. shows a very well developed diffusion current when the concentration of -2 tellurium is smaller than about 0.5 millimolar. With greater concentrations (curves c and d) the main wave divides into two parts, the height of the first part being almost independent of the concentration of -2 tellurium. This behavior is indicative of film formation on the surface of the dropping electrode. The diffusion current between -0.5 v. and -0.9 v. is directly proportional to the concentration of telluride ion up to 1 millimolar, and the diffusion current constant $i_d/(Cm^{2/3}t^{1/6})$ was found to be 3.5 ± 0.1 .

By controlled potential coulometric analysis at -0.6 v. and at -1.12 v. in 1 *N* sodium hydroxide the oxidation at both potentials was found to involve 2 electrons. During these experiments the surface of the mercury electrode (functioning as anode) became coated with a black deposit which slowly dissolved to produce a solution with the deep violet color characteristic of the polytelluride ions.¹⁵ Hence the primary reaction when the concentration of telluride ion is large appears to be



and the element then dissolves relatively slowly to

(15) D. M. Yost and H. Russell, "Systematic Inorganic Chemistry," Prentice-Hall, Inc., New York, N. Y., 1944.

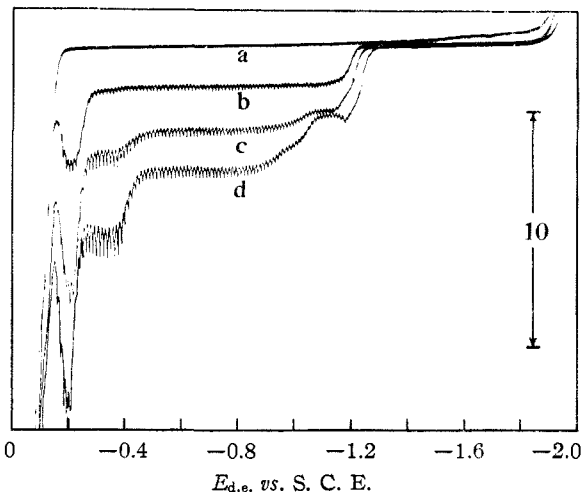
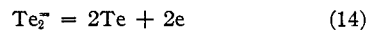

Fig. 5.—Polarograms of -2 tellurium in 1 *N* sodium hydroxide containing 0.003% gelatin. The concentrations of -2 tellurium were (a) 0, (b) 0.327, (c) 0.642 and (d) 0.945 millimolar. Arrow distance is 10 μ a.

form ditelluride ion (and probably higher polytellurides)



The ditelluride ion is subsequently oxidized according to



With small concentrations of telluride ion there appears to be little, if any, intermediate formation of polytelluride.

Curves c and d in Fig. 5 also exhibit another wave at -0.4 v., which is due to oxidation above the elemental state. Attempts to identify the oxidation product by coulometric analysis on a macro scale were unsuccessful. Controlled potential oxidation of telluride solutions at -0.24 v. indicated only a 2-electron oxidation, and no evidence of further oxidation was obtained when electrolysis was continued for several hours after the current had fallen to zero. When the electrolysis is performed on the macro scale, the elemental tellurium apparently is produced in a much less reactive form than under the conditions extant in electrolysis with the dropping electrode. The half-wave potential of this wave (-0.42 v. *vs.* S.C.E.) is quite close to the known¹³ standard potentials of the half reactions

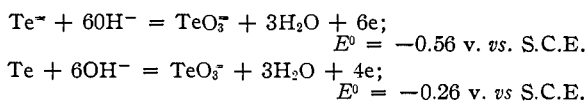

Hence it probably does represent oxidation to tellurite ion, but the relatively small value of the limiting current indicates that the oxidation is rate controlled and very incomplete.

Tracings of polarograms of -2 tellurium in solutions of various pH are shown in Fig. 6. The anodic wave persists over the entire pH range, and its half-wave potential becomes less negative with

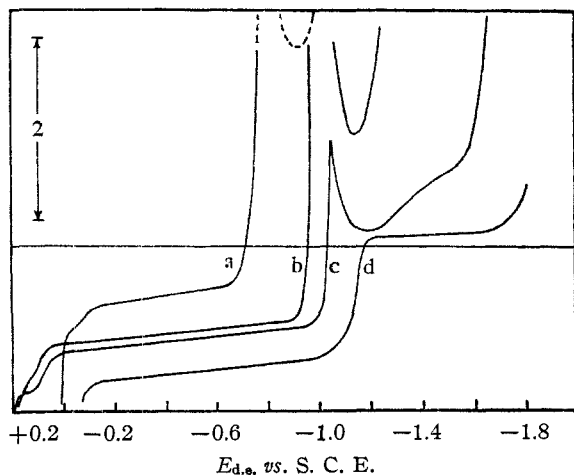
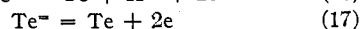
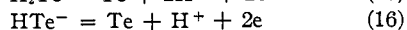
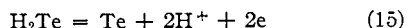

Fig. 6.—Polarograms of -2 tellurium in solutions of various pH . Approximately 0.19 millimolar -2 tellurium and 0.003% gelatin in (a) $1 N$ hydrochloric acid, pH 0.1 ; (b) $0.5 M$ citrate buffer, pH 3.3 ; (c) $0.5 M$ citrate buffer, pH 5.1 ; and (d) $1 M$ ammonium chloride-ammonia, pH 8.5 . The horizontal line is the galvanometer zero. Arrow distance is $2\mu a$.

decreasing pH . When the pH is smaller than about 8 the polarograms display very large *cathodic* maxima, and curve *c* at pH 5.1 also shows an ill-defined *cathodic* wave following the maximum. It was known that in spite of precautions that were taken a small amount of the telluride ion underwent air-oxidation during the preparation of these solutions, and the cathodic phenomena are doubtless caused by the oxidized species (probably tellurite ion). The cathodic maximum in the more acid solutions, which persisted in the presence of gelatin, is much too large to be attributed to faradaic reduction of the small concentration of the oxidized species, and it probably is due to catalytic reduction of hydrogen ion.

Depending on the pH , the anodic wave results from one of the reactions



and any one of them may be used to derive a relation between the anodic half-wave potential and pH . When reaction 15 is used the equation relating $E_{1/2}$ to hydrogen ion concentration is identical with Eqn. 11. When reaction 17 is employed, the relation becomes

$$E_{1/2} = E^0 + \frac{0.059}{2} \log \frac{Z}{K_1 K_2} - \frac{0.059}{2} \log \frac{C}{2} \quad (18)$$

where E^0 is the standard potential of reaction 17, K_1 and K_2 are the ionization constants of hydrogen telluride, and $Z = C_{H^+}^2 + K_1 C_{H^+} + K_1 K_2$. The additional $K_1 K_2$ term is present because the

standard potential of reaction 17 differs from that of reaction 15 by $0.059/2 \log K_1 K_2$.

Direct experimental values for the standard potentials of reactions 15, 16 and 17, and for K_2 , do not exist. By estimating values for the entropy of formation and the free energy of solution of hydrogen telluride Latimer¹³ calculated that E^0 for reaction 15 is -0.69 v. vs. the standard hydrogen electrode, or -0.93 v. vs. S.C.E. From conductivity measurements of Hlasko,¹⁴ $K_1 = 2.3 \times 10^{-3}$. These values were employed with Eqn. 11 to compute the theoretical curves *c* and *d* in Fig. 4. Curve *c* was computed by using Latimer's assumption¹³ that $K_2 = 10^{-5}$, and curve *d* resulted when K_2 was assumed to be 10^{-11} . The agreement between the experimental points and the theoretical curve based on $K_2 = 10^{-11}$ is very good over the pH range from about 3 to 14 . The discrepancy between the observed and theoretical half-wave potentials at pH less than 3 reflects the difficulty of accurately measuring the half-wave potential in the presence of the large cathodic maximum.

It is evident that the oxidation of -2 tellurium occurs practically reversibly at the dropping electrode, that Latimer's estimate of E^0 for reaction 15 is essentially correct, but that K_2 for hydrogen telluride is of the order of 10^{-11} .

Since the half-wave potential of telluride ion is 0.3 v. more negative than that of selenide ion, the simultaneous determination of the two is quite feasible and should also be successful in the presence of sulfide ion.

Summary

The polarographic behavior of -2 selenium and -2 tellurium has been studied over the pH range 0 to 14 . With both elements well-developed anodic waves are obtained at all pH values. By controlled potential coulometric electrolysis on a macro scale the reactions with both element were found to be a 2-electron oxidation.

In the case of selenium the primary anodic reaction is the oxidation of the mercury of the dropping electrode, followed by precipitation of mercuric selenide. The reactions occur reversibly and the observed half-wave potentials agree well with the theoretical values.

In contradistinction to sulfide and selenide ions, telluride ion does not "depolarize" the dropping electrode, but rather the anodic wave results from oxidation of the -2 tellurium itself to the elemental state. The oxidation occurs practically reversibly. In strongly alkaline medium telluride ion displays an additional anodic wave due to a rate controlled and incomplete oxidation to tellurite ion.